

Saffire™ LX-L

SMART Latch RFID Cylindrical Lock



Features and benefits

- Operates with a completely sealed, high performance contactless reader
- Low battery indicator for preventative maintenance
- RFID credentials are easy-to-use and hard-to-lose
- Eliminates cost and hassle of managing keys
- Expand your access control as your multihousing community grows
- Available with third-party integrations to create a modern living experience
- Ideal for new construction or retrofits
- Suitable for small to large-scale multihousing properties
- Single system to control resident units, perimeter entries, amenity spaces and storage units

Overview

Saffire LX-L Smart Latch Lock is a sleek, contemporary design RFID lock with a small footprint designed with the latest connectivity and security conveniences for multihousing properties. The Saffire LX-L provides an easy-to-use, secure, and flexible solution that is both visually attractive and high performing. With its sleek curves and clean aesthetics, Saffire LX-L results in a lock design that integrates seamlessly with your property décor.

Convenient Mobile Access

The Saffire LX-L is equipped with Bluetooth

Low Energy (BLE) Technology, which gives today's residents the added convenience of using a smart device in addition to fobs to access units, common areas and the perimeter. Our key delivery platform issues and authenticates mobile credentials through BlueSky, dormakaba's mobile access app.

Intuitive Access Management Software

The Saffire LX-L is managed by dormakaba Community™ access management software. Community provides intuitive management of residences, amenities, common areas and perimeter access from a single platform. Community offers the

convenience of both RFID credentials and BLE mobile access keys for a seamless experience with no need for additional software.

Security features

- BHMA Grade 2
- Maintains lock programming and audit records
- Staff monitoring – RFID keycard audits
- Tamperproof design
- No touring – Update access without visiting lock

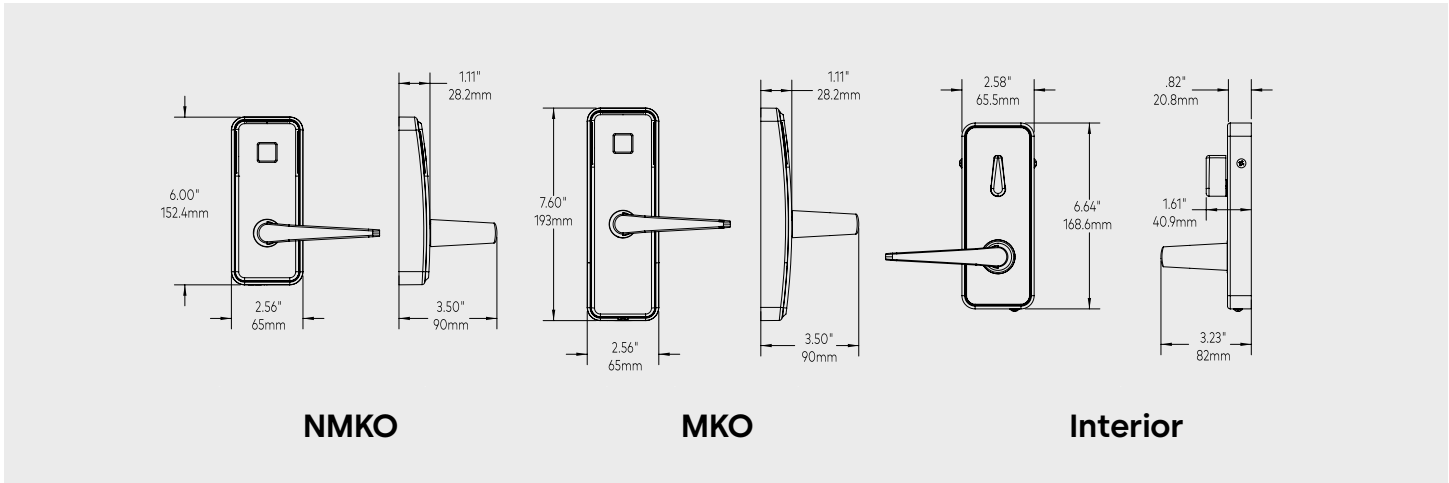

Mechanical Features

Description	Electronic lockset with clutch mechanism and built-in contactless RFID reader
Handing	Field reversible
Lever	Essen, Troy and Von levers (field reversible), custom lever options available, consult with your sales representative.
Finishes**	Satin chrome, satin brass, oil-rubbed bronze, bright chrome, satin nickel and black Polycarbonate finish: black ** dormakaba utilizes PVD (physical vapor deposition) finishes in some instances
Door Thickness	From 1 3/8" to 2 1/8" (35mm to 54mm)
Locking Options	ANSI/BHMA Grade 2
Batteries	3 AA for up to 2 years. Low battery indicator for preventative maintenance
Concealed key override	Electronic battery backup
Online Configuration	Community RX

Mobile Access

BLE BLE enabled. Ready to operate using dormakaba mobile access solutions.

Lock Operation

No Touring	New credentials automatically cancel prior credential when brought to lock
Electronic Key Levels	User defined, customizable key levels & key groups tailored for your community. Individual levels for residents, leasing, maintenance, services and vendors.
Date/time stamp	Real time: date and hours/minutes; automatically adjusts for daylight savings time
Programming & audit trail downloading	Handheld unit incorporating Near Field Communication interface and FW/Security features
Lockout mode	Set by authorized key
Credentials accepted	- Mifare Ultralight C: Guest Keys - Mifare DESFire: Guest and Staff Keys (DESFire EV3 2k, DESFire EV2 4k, DESFire EV3 4k, DESFire EV3 8k) - Mifare Plus: Guest Keys (Mifare Plus 1K), Staff Keys (Mifare Plus S 1k, Mifare Plus S 2k, Mifare Plus S 4k) - Mifare Classic: Guest Keys (Mini), Staff (Classic 1k, Classic 4k)
Feedback LED	Light indicators
Diagnostics	Handheld display
Audit memory	Most recent 4,000 events

Certifications & Testing

Certification	BHMA A156.2; BHMA 156.25
Accessibility Standard	Complies with 2010 ADA Standards for Accessible Design - Art. 309.4 (Operable Parts). For models with long lever only. Lock shall be properly aligned with the mortise or latch and must be installed strictly according to the dormakaba installation instructions and the ADA Standards and Regulations applicable for each facility, to be able to fulfill compliance with ADA requirements.
Fire Rating	Meets UL 10C and ULC S-104, on fire door rated up to and including 3 hours
Electronics	Compliant with RE Directive 2014/53/EU for electromagnetic compatibility and FCC part 15 and RSS-247 Industry Canada requirements.
Environmental Operating Conditions	-31°F to +158°F (-35°C to +70°C), 0% to 90% non-condensing humidity at 86°F (30°C) Meets IP54

Warranty

Warranty	Two years
-----------------	-----------

Any questions? We would be happy to advise you.

Contact us at: 1 800 849 8324